



(19) **United States**

(12) **Patent Application Publication**
HAN et al.

(10) **Pub. No.: US 2009/0027312 A1**

(43) **Pub. Date: Jan. 29, 2009**

(54) **ORGANIC LIGHT EMITTING DISPLAY**

(52) **U.S. Cl. 345/76**

(76) **Inventors: Min Koo HAN, Seoul (KR); Sang Myeon Han, Seoul (KR)**

(57) **ABSTRACT**

An organic light emitting display that can minimize degradation of a drive transistor comprising a first switching element whose control electrode is electrically coupled to a scan line, being electrically coupled between a data line and a first voltage line for transmitting a data signal; a drive transistor whose control electrode is electrically coupled to the first switching element, being electrically coupled between the first and second voltage lines; an organic light emitting diode electrically coupled to the drive transistor, displaying an image by a current supplied through the drive transistor; a first capacitive element electrically coupled between the control electrode of the drive transistor and the first switching element; a second capacitive element electrically coupled between the first capacitive element and the second voltage line; a second switching element electrically coupled between the first voltage line and the control electrode of the drive transistor; a third switching element electrically coupled between the first switching element and the drive transistor; a fourth switching element electrically coupled between the control electrode of the drive transistor and the second voltage line; and a fifth switching element electrically coupled between the drive transistor and the second voltage line.

Correspondence Address:
IPHORGAN, LTD.
1130 LAKE COOK ROAD, SUITE 240
BUFFALO GROVE, IL 60089 (US)

(21) **Appl. No.: 12/168,204**

(22) **Filed: Jul. 7, 2008**

(30) **Foreign Application Priority Data**

Jul. 23, 2007 (KR) 10-2007-0073427

Publication Classification

(51) **Int. Cl. G09G 3/30 (2006.01)**

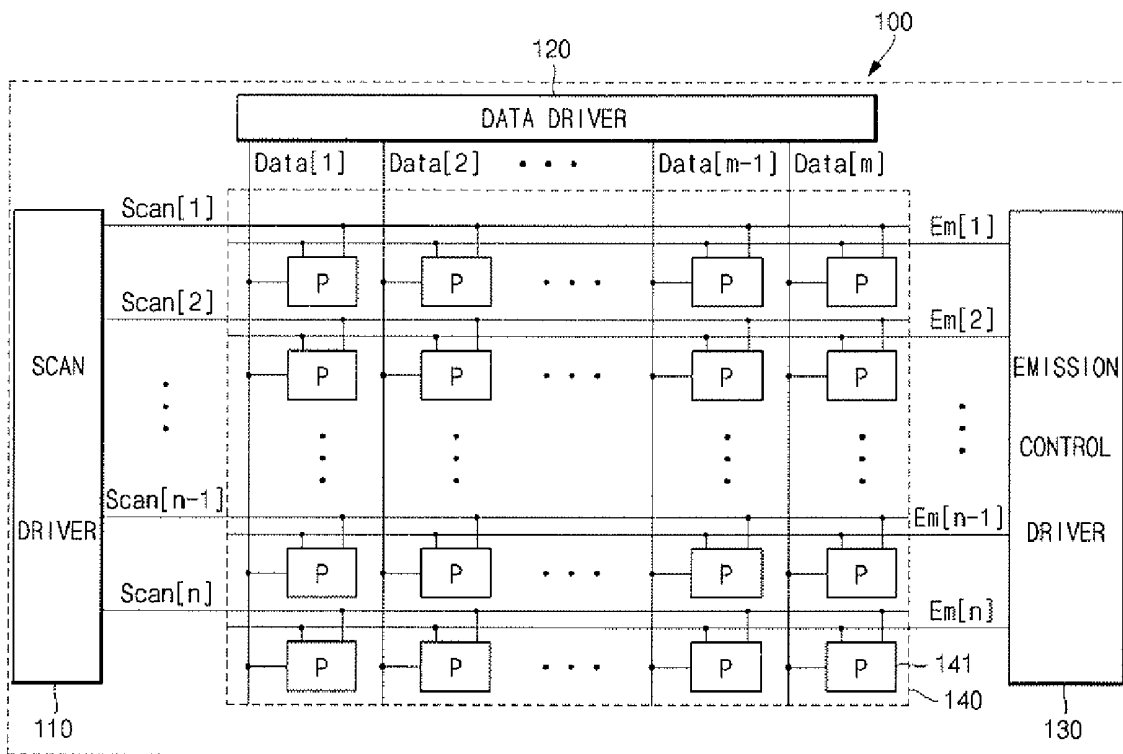

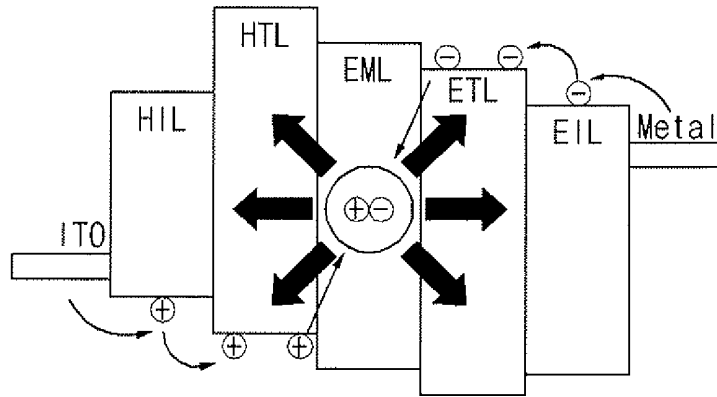

FIG. 1

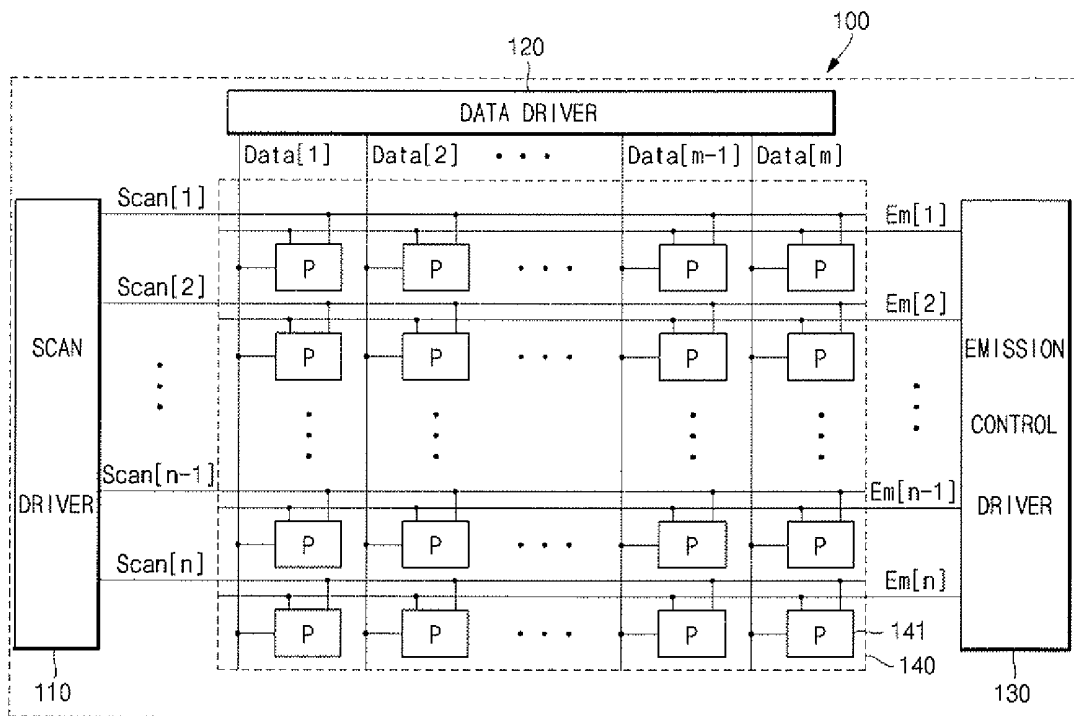

FIG. 2

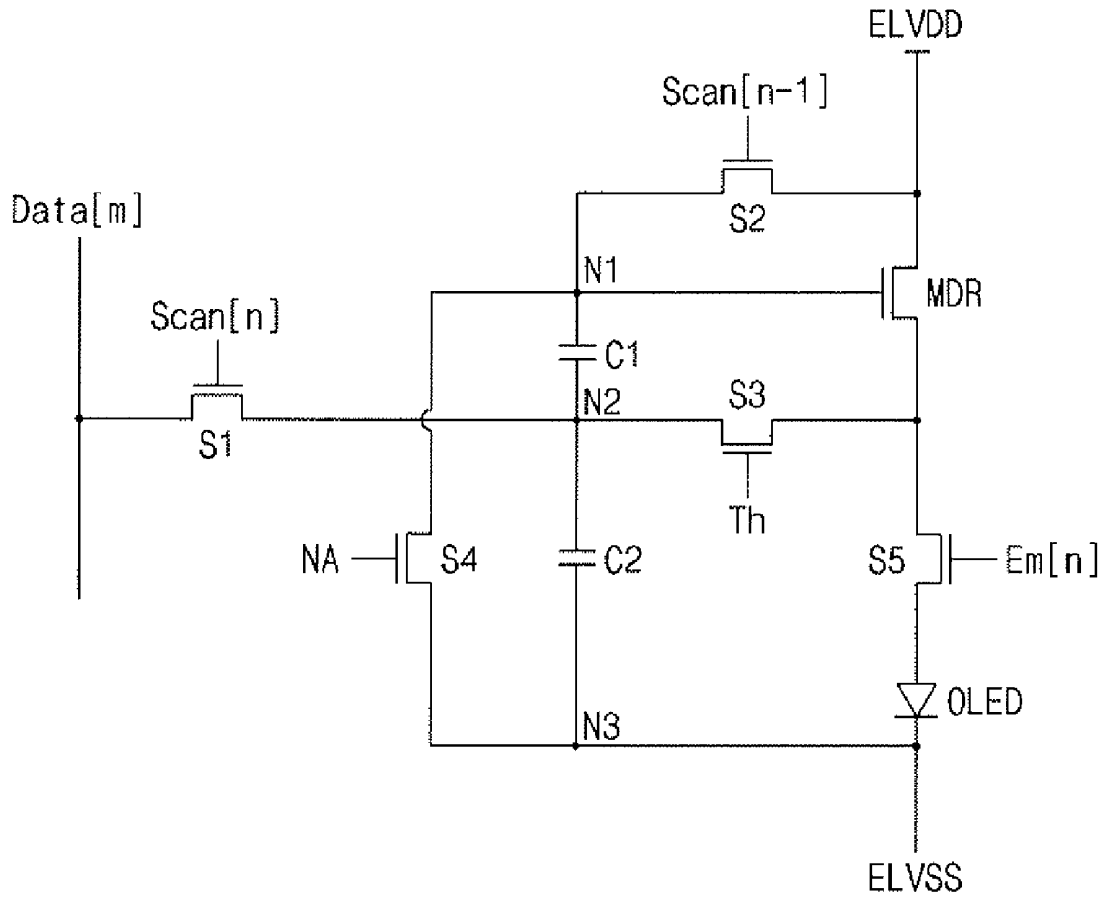

FIG. 3

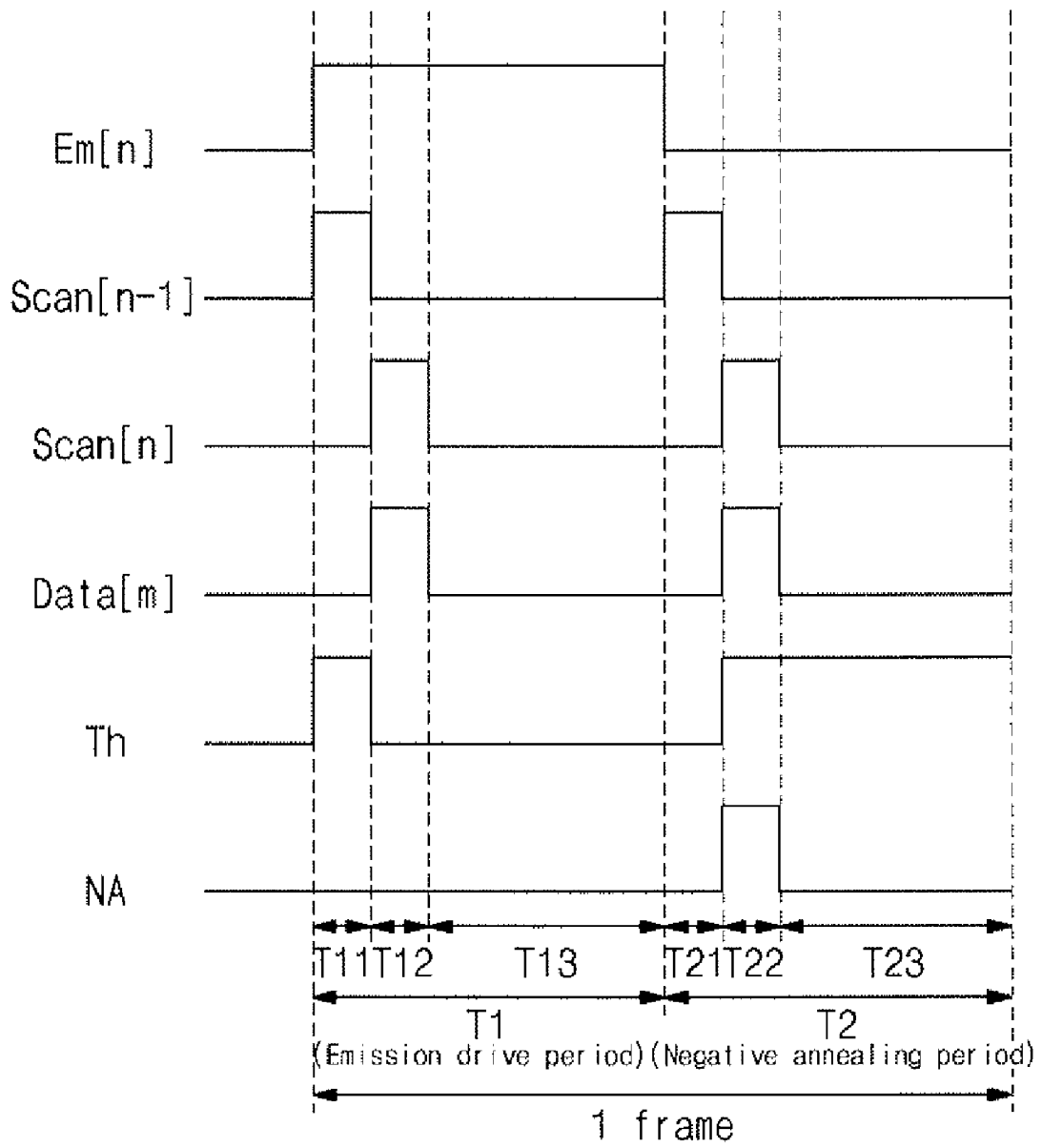

FIG. 4

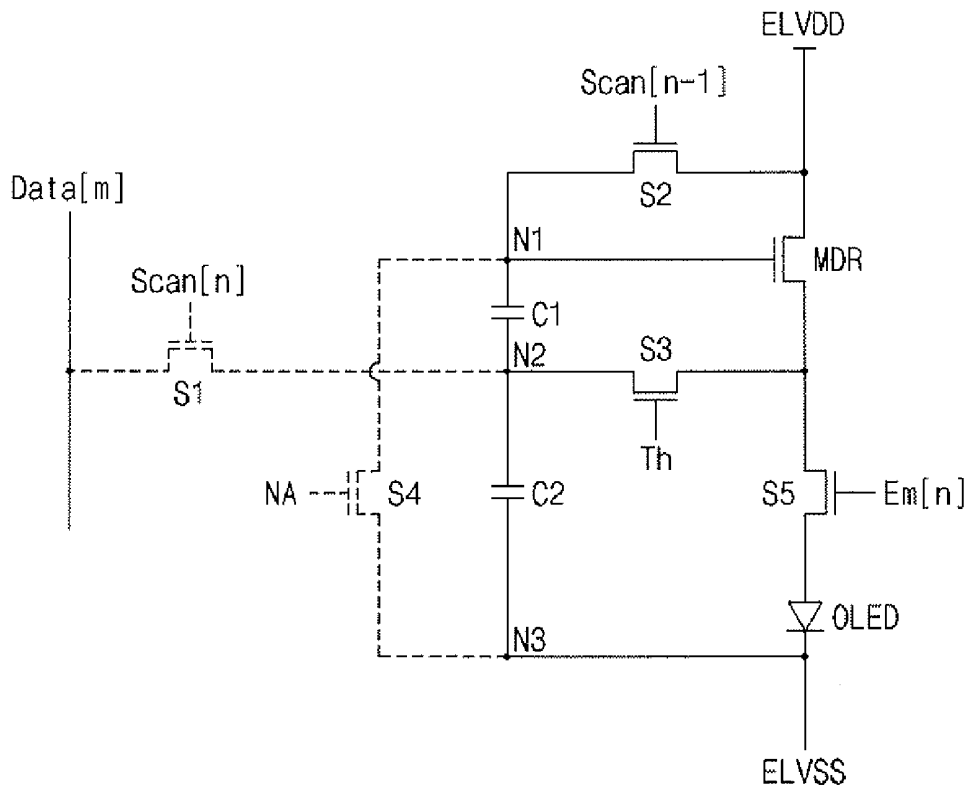

FIG. 5

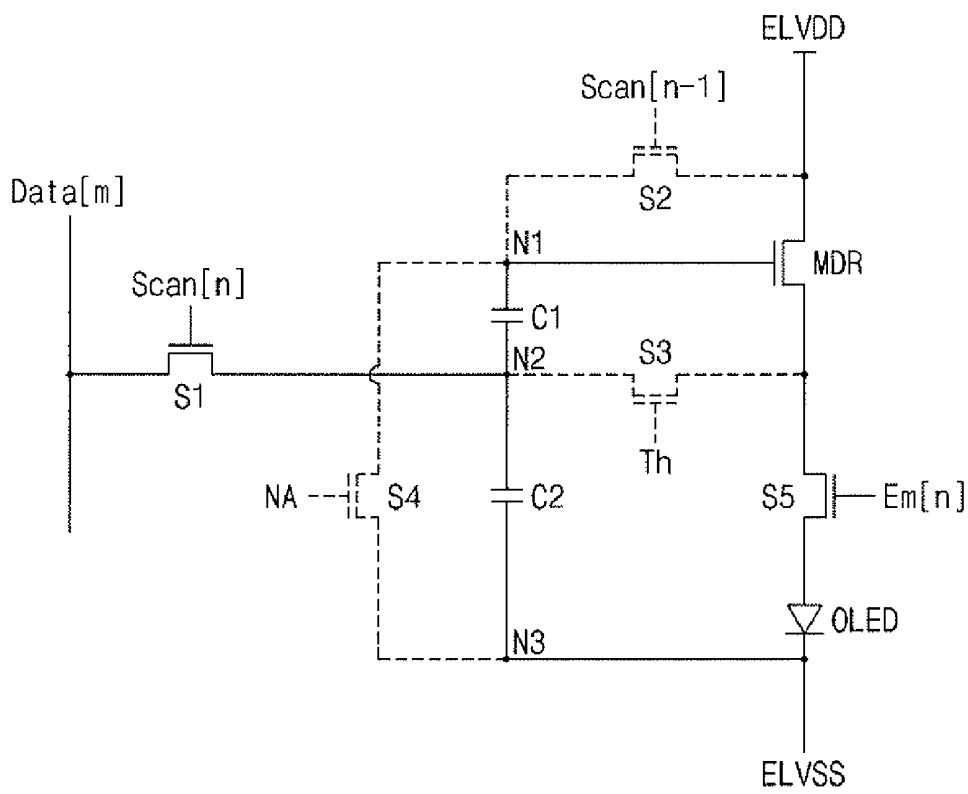

FIG. 6

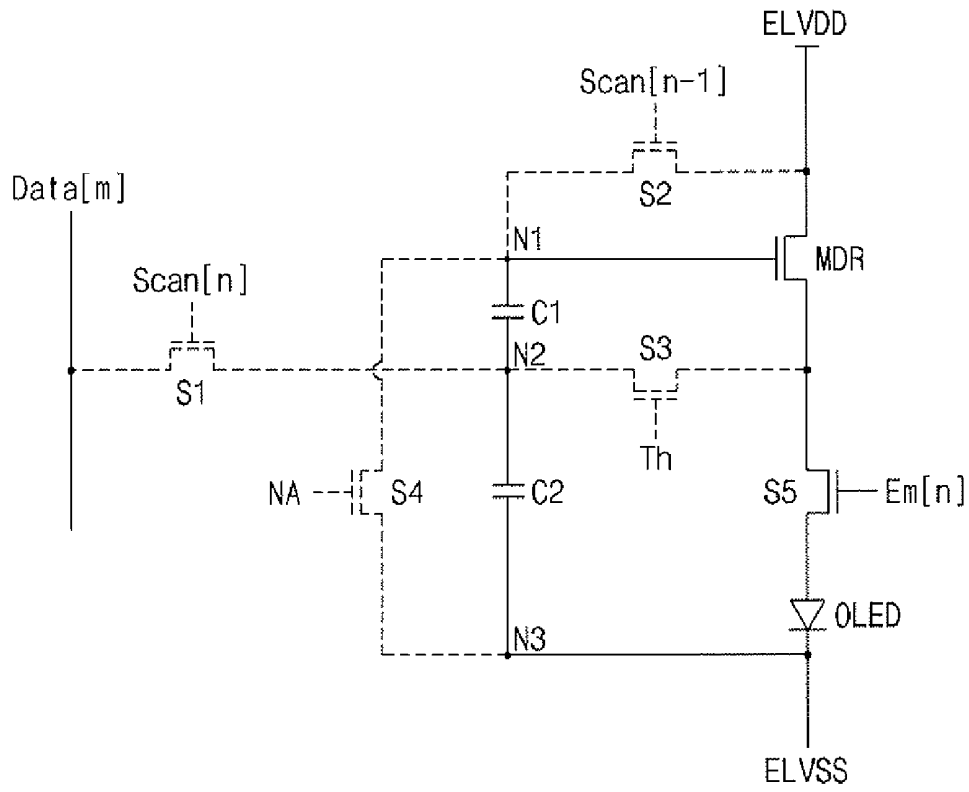

FIG. 7

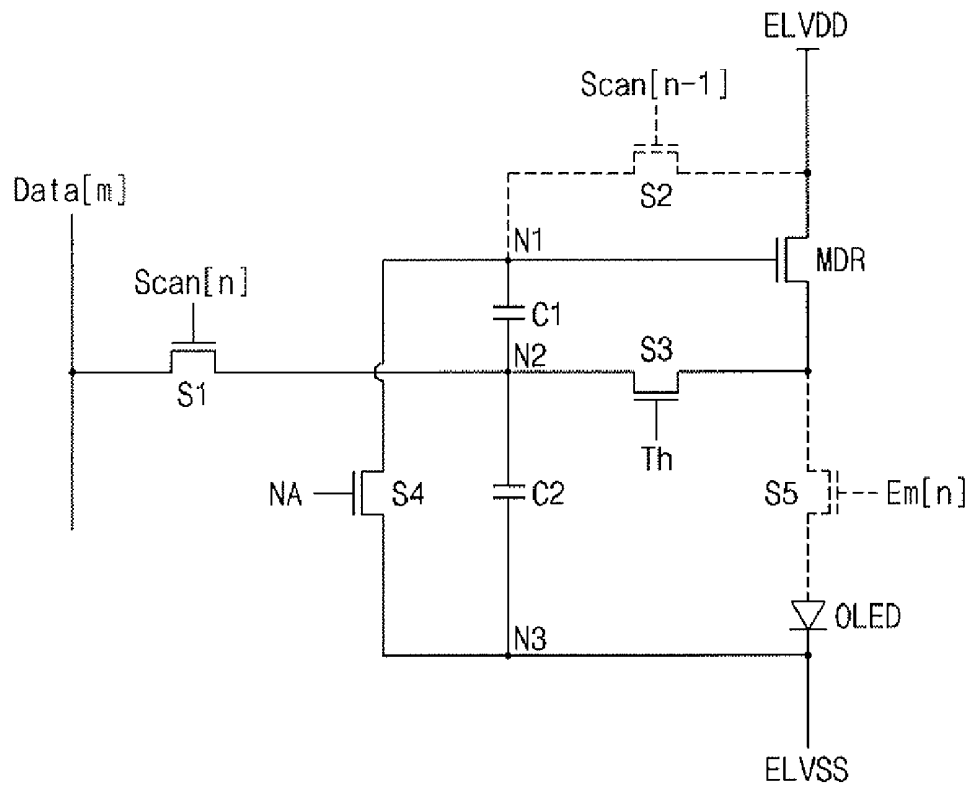

FIG. 8

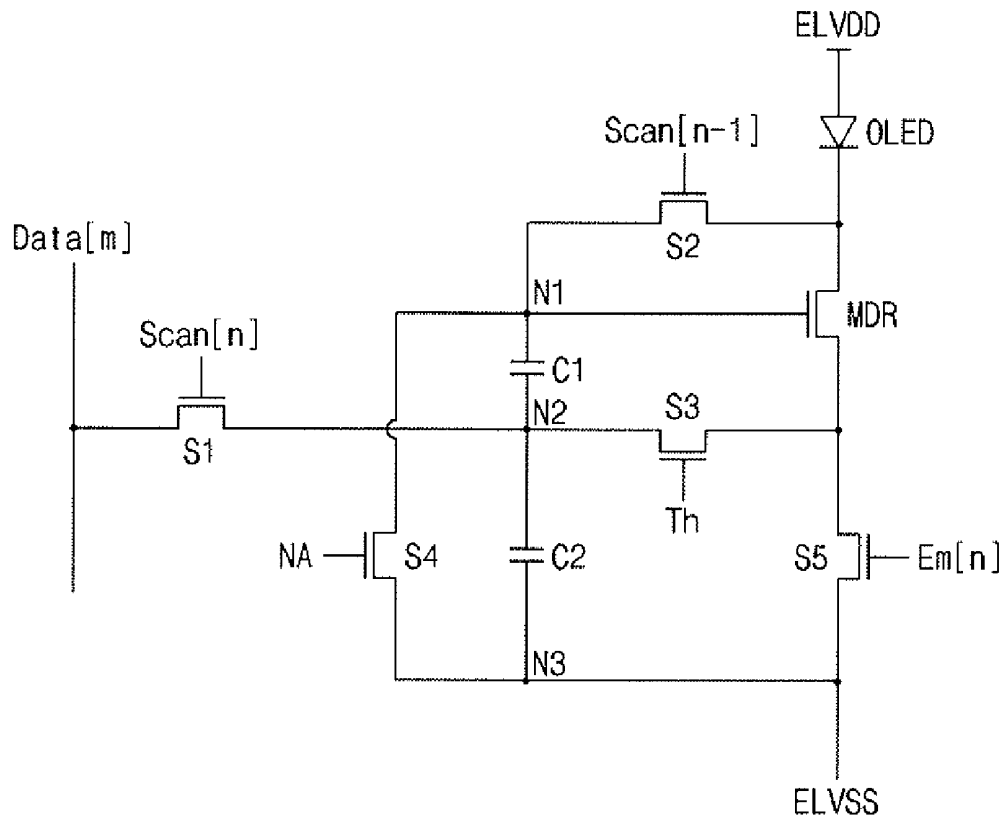

FIG. 9

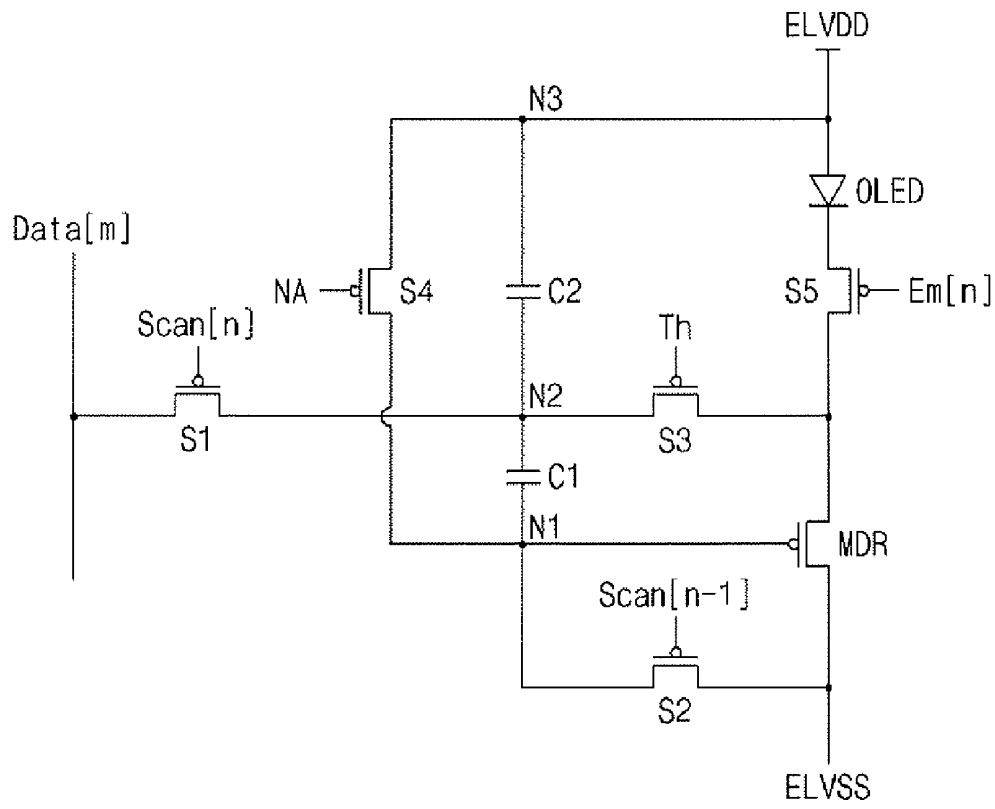

FIG. 10

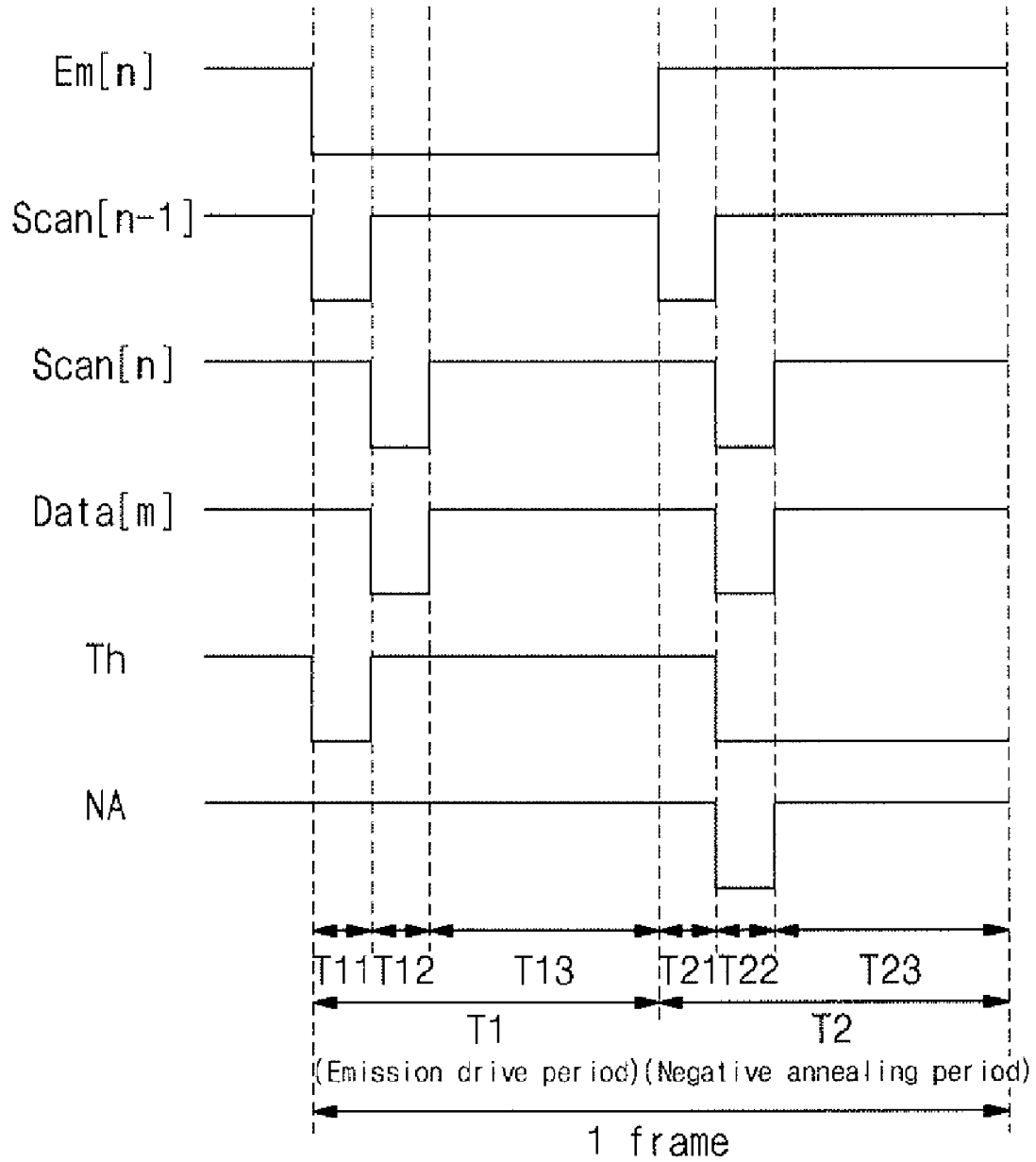

FIG. 11

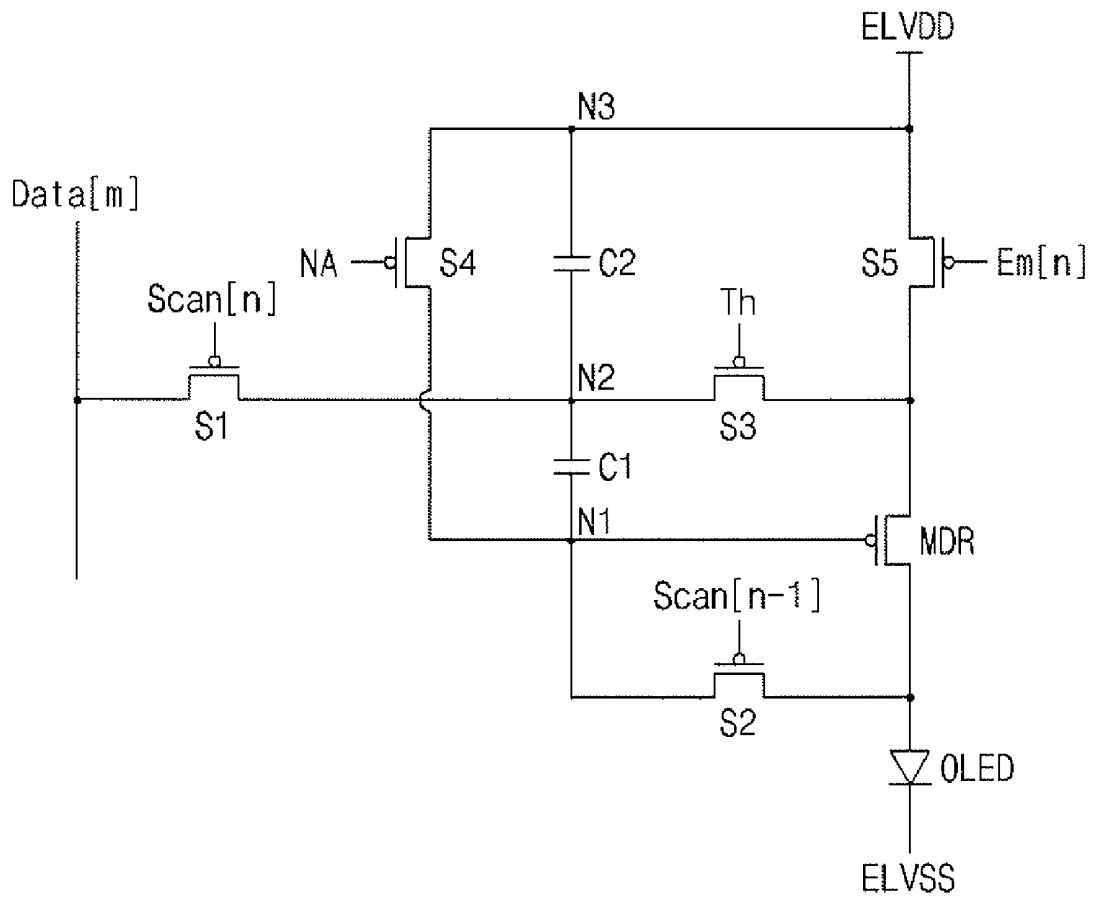

FIG. 12

ORGANIC LIGHT EMITTING DISPLAY

CROSS-REFERENCE TO RELATED APPLICATIONS

[0001] This application is based on and claims priority to Korean Patent Application No. 10-2007-0073427 filed on Jul. 23, 2007 in the Korean Intellectual Property Office (KIPO), the entire contents of which are hereby incorporated by reference.

BACKGROUND OF THE INVENTION

[0002] 1. Field of the Invention

[0003] The present invention relates to an organic light emitting display, and more particularly, to an organic light emitting display that can minimize degradation of a drive transistor in a pixel circuit of the organic light emitting display and brightness change of an organic light emitting diode caused by the degradation.

[0004] 2. Description of the Related Art

[0005] Generally, a conventional organic light emitting display is a display device emitting light by electrically exciting fluorescent or phosphorescent materials. The organic light emitting display displays images by driving N×M number of organic light emitting cells. The organic light emitting cell includes an anode (ITO), an organic thin film and a cathode (metal) as shown in FIG. 1. The organic thin film has a multi-layered structure including an emitting layer (EML), an electron transport layer (ETL) and a hole transport layer (HTL) for improving lighting efficiency with a balanced combination of an electron and a hole. Further, the organic thin film may include separate an electron injecting layer (EIL) and a hole injection layer (HIL).

[0006] A technique for driving the organic light emitting cell includes a passive matrix (PM) technique, and an active matrix (AM) technique using a thin film transistor (TFT) or a metal oxide silicon thin film transistor (MOSFET). The passive matrix technique drives a light emitting cell by forming an anode to be intersected with a cathode and selecting a line. The active matrix technique is a driving technique that connects the transistor and the capacitor to respective indium tin oxide (ITO) pixel electrodes to maintain a voltage by a capacity of a capacitor.

[0007] The transistor used in this active matrix technique is an amorphous silicon thin film transistor or polycrystalline silicon thin film transistor. When the amorphous silicon thin film transistor is used as a drive element, current driving power is relatively low. However, uniformity of the display is excellent and the transistor is advantageous in large scale process. However, a threshold voltage of the drive transistor in the pixel circuit for flowing current is gradually increased because the silicon structure is damaged according to current flow caused by a voltage applied to a control electrode thereof. As shown in a transistor current equation of the following equation 1, an amount of current applied to the organic light emitting diode is decreased according to the increase of the threshold voltage. Accordingly, brightness of each pixel is decreased. Thus, there is a problem that brightness of the organic light emitting display is gradually decreased with the lapse of time.

[0008] Moreover, there is another problem that the threshold voltage degradation of each pixel circuit is changed according to a data voltage that has been already applied to

each pixel circuit, the entire brightness of the organic light emitting display becomes non-uniform.

[Equation 1]

$$I_{OLED} = \frac{\beta}{2}(V_{GS} - V_{TH})^2$$

1

[0009] In the above equation 1, I_{OLED} is a current flowing in a drive transistor and an organic light emitting diode, V_{GS} is a voltage between gate and source of the drive transistor, V_{TH} is a threshold voltage of the drive transistor, and β is an electric conductivity of the drive transistor.

SUMMARY OF THE INVENTION

[0010] Accordingly, an object of the present invention is to provide an organic light emitting display that can minimize threshold voltage change of a drive transistor, in other words, degradation phenomenon and improve an overall brightness uniformity of the display by dividing an image display period of one frame into first and second periods, and applying a positive (or negative) voltage as a data signal to a control electrode of a drive transistor in the first period to allow an organic light emitting diode to emit light, and, in the second period, applying a negative (or positive) voltage opposite to the voltage applied to the control electrode of the drive transistor in the first period to turn off the organic light emitting diode, and simultaneously, negatively annealing the drive transistor.

[0011] Another object of the present invention is to provide an organic light emitting display that can prevent motion blur phenomenon and provide a high contrast ratio by controlling a ratio of an emitting drive period to a negative annealing period in an image display period of one frame to 1:1 or other ratio and displaying a first image between one frame and a next frame naturally.

[0012] A still another object of the present invention is to provide an organic light emitting display that can compensate a threshold voltage of a drive transistor by connecting the drive transistor in a diode structure and storing the threshold voltage of the drive transistor in a capacitive element electrically coupled to the drive transistor and applying a summed voltage of the threshold voltage and the data voltage to the control electrode of the drive transistor when a data voltage is applied to the drive transistor.

[0013] According to one embodiment of the invention, an organic light emitting display is provided. The organic light emitting display includes a first switching element, a drive transistor, an organic light emitting diode, a first capacitive element, a second capacitive element, a second switching element, a third switching element, a fourth switching element, and a fifth switching element. The first switching element having a control electrode is electrically coupled to a scan line, being electrically coupled between a data line and a first voltage line for transmitting a data signal. The drive transistor having a control electrode is electrically coupled to the first switching element, being electrically coupled between the first voltage line and a second voltage line. The organic light emitting diode electrically coupled to the drive transistor, displaying an image by a current supplied through the drive transistor. The first capacitive element electrically coupled between the control electrode of the drive transistor and the first switching element. The second capacitive ele-

ment electrically coupled between the first capacitive element and the second voltage line. The second switching element electrically coupled between the first voltage line and the control electrode of the drive transistor. The third switching element electrically coupled between the first switching element and the drive transistor. The fourth switching element electrically coupled between the control electrode of the drive transistor and the second voltage line. The fifth switching element electrically coupled between the drive transistor and the second voltage line.

[0014] A first electrode of the first switching element may be electrically coupled to the data line, and a second electrode of the first switching element may be electrically coupled between a first electrode of the third switching element and a second electrode of the first capacitive element and a first electrode of the second capacitive element.

[0015] A control electrode of the second switching element may be electrically coupled to a previous scan line, and a first electrode of the second switching element may be electrically coupled between a first electrode of the fourth switching element and a first electrode of the first capacitive element and the control electrode of the drive transistor, and a second electrode of the second switching element may be electrically coupled between the first voltage line and the first electrode of the drive transistor.

[0016] A control electrode of the third switching element may be electrically coupled to a threshold voltage compensation line, and a first electrode of the third switching element may be electrically coupled between a second electrode of the first switching element and the second electrode of the first capacitive element and the first electrode of the second capacitive element, and a second electrode of the third switching element may be electrically coupled between the drive transistor and the fifth switching element.

[0017] A control electrode of the fourth switching element may be electrically coupled to a negative annealing line, and a first electrode of the fourth switching element may be electrically coupled between the control electrode of the drive transistor and the first electrode of the second switching element and the first electrode of the first capacitive element, and a second electrode of the fourth switching element may be electrically coupled to the second voltage line.

[0018] A control electrode of the fifth switching element may be electrically coupled to an emission control line, and a first electrode of the fifth switching element may be electrically coupled between the second electrode of the drive transistor and the second electrode of the third switching element, and a second electrode of the fifth switching element may be electrically coupled to the second voltage line.

[0019] An anode of the organic light emitting diode may be electrically coupled to the fifth switching element, a cathode of the organic light emitting diode may be electrically coupled to the second voltage.

[0020] An anode of the organic light emitting diode may be electrically coupled to the first voltage line, a cathode of the organic light emitting diode may be electrically coupled between the first electrode of the drive transistor and the second electrode of the second switching element.

[0021] A first electrode of the first capacitive element may be electrically coupled between the first electrode of the second switching element and the control electrode of the drive transistor and the first electrode of the fourth switching element, and a second electrode of the first capacitive element may be electrically coupled between the second electrode of the

the first switching element and the first electrode of the third switching element and the first electrode of the second capacitive element.

[0022] A first electrode of the second capacitive element may be electrically coupled between the second electrode of the first capacitive element and the second electrode of the first switching element and the first electrode of the third switching element, and a second electrode of the second capacitive element may be electrically coupled between the second electrode of the fourth switching element and the second voltage line.

[0023] The first, second, third, fourth and fifth switching elements and the drive transistor are an N type channel transistor.

[0024] When the second and fifth switching elements are turned off and the first, third and fourth switching elements are turned on during an image display period of one frame, a data signal may be applied to the second electrode of the drive transistor, and the second voltage may be applied to the control electrode of the drive transistor.

[0025] According to another embodiment of the invention, an organic light emitting display is provided. The organic light emitting display includes a first switching element, a drive transistor, an organic light emitting diode, a first capacitive element, a second capacitive element, a second switching element, a third switching element, a fourth switching element, and a fifth switching element. The first switching element having a control electrode is electrically coupled to a scan line, being electrically coupled between a data line and a first voltage line for transmitting a data signal. The drive transistor having a control electrode is electrically coupled to the first switching element, being electrically coupled between the first voltage line and a second voltage line. The organic light emitting diode electrically coupled to the drive transistor, displaying an image by a current supplied through the drive transistor. The first capacitive element electrically coupled between the control electrode of the drive transistor and the first switching element. The second capacitive element electrically coupled between the first capacitive element and the first voltage line. The second switching element electrically coupled between the second voltage line and the control electrode of the drive transistor. The third switching element electrically coupled between the first switching element and the drive transistor. The fourth switching element electrically coupled between the control electrode of the drive transistor and the first voltage line. The fifth switching element electrically coupled between the drive transistor and the first voltage line.

[0026] A first electrode of the first switching element may be electrically coupled to the data line, and a second electrode of the first switching element may be electrically coupled between a first electrode of the third switching element and a first electrode of the first capacitive element and a second electrode of the second capacitive element.

[0027] A control electrode of the second switching element may be electrically coupled to a previous scan line, and a first electrode of the second switching element may be electrically coupled between a second electrode of the fourth switching element and a second electrode of the first capacitive element and the control electrode of the drive transistor, and a second electrode of the second switching element may be electrically coupled between the second voltage line and the second electrode of the drive transistor.

[0028] A control electrode of the third switching element may be electrically coupled to a threshold voltage compensation line, and a first electrode of the third switching element may be electrically coupled between a second electrode of the first switching element and the first electrode of the first capacitive element and the second electrode of the second capacitive element, and a second electrode of the third switching element may be electrically coupled between the drive transistor and the fifth switching element.

[0029] A control electrode of the fourth switching element may be electrically coupled to a negative annealing line, and a first electrode of the fourth switching element may be electrically coupled to the first voltage line, and a second electrode of the fourth switching element may be electrically coupled between the control electrode of the drive transistor and the first electrode of the second switching element and the second electrode of the first capacitive element.

[0030] A control electrode of the fifth switching element may be electrically coupled to an emission control line, and a first electrode of the fifth switching element may be electrically coupled to the first voltage line, and a second electrode of the fourth switching element may be electrically coupled between the first electrode of the drive transistor and the second electrode of the third switching element.

[0031] An anode of the organic light emitting diode may be electrically coupled between the second electrode of the drive transistor and the second electrode of the second switching element, and a cathode of the organic light emitting diode may be electrically coupled to the second voltage.

[0032] An anode of the organic light emitting diode may be electrically coupled to the first voltage line, a cathode of the organic light emitting diode may be electrically coupled to the first electrode of the fifth switching element.

[0033] A first electrode of the first capacitive element may be electrically coupled between the second electrode of the first switching element and the first electrode of the third switching element and the second electrode of the second capacitive element, and a second electrode of the first capacitive element may be electrically coupled between the first electrode of the second switching element and the control electrode of the drive transistor and the second electrode of the fourth switching element

[0034] A first electrode of the second capacitive element may be electrically coupled between the first electrode of the fourth switching element and the first voltage line, and a second electrode of the second capacitive element may be electrically coupled between the first electrode of the first capacitive element and the second electrode of the first switching element and the first electrode of the third switching element.

[0035] The first, second, third, fourth and fifth switching elements and the drive transistor are a P type channel transistor.

[0036] When the second and fifth switching elements are turned off and the first, third and fourth switching elements are turned on during an image display period of one frame, a data signal may be applied to the first electrode of the drive transistor, and the first voltage may be applied to the control electrode of the drive transistor.

BRIEF DESCRIPTION OF THE DRAWING FIGURES

[0037] The above and other objects, features and advantages of the present invention will be more apparent from the

following detailed description taken in conjunction with the accompanying drawing, in which:

[0038] FIG. 1 is a schematic view illustrating a usual organic light emitting diode;

[0039] FIG. 2 is a block view illustrating a construction of an organic light emitting display according to the present invention;

[0040] FIG. 3 is a circuit diagram illustrating a pixel circuit of an organic light emitting display according to one exemplary embodiment of the present invention;

[0041] FIG. 4 is a drive timing diagram of the pixel circuit as shown in FIG. 3;

[0042] FIG. 5 is a circuit diagram illustrating an operation of the pixel circuit during a threshold voltage compensation period T_{11} of an emitting drive period T_1 of the pixel circuit as shown in FIG. 4;

[0043] FIG. 6 is a circuit diagram illustrating an operation of the pixel circuit during a data recording period T_{12} of the emitting drive period T_1 of the pixel circuit as shown in FIG. 4;

[0044] FIG. 7 is a circuit diagram illustrating an operation of the pixel circuit during an emitting period T_{13} of the emitting drive period T_1 of the pixel circuit as shown in FIG. 4;

[0045] FIG. 8 is a circuit diagram illustrating an operation of the pixel circuit during a negative annealing period T_2 of the pixel circuit as shown in FIG. 4;

[0046] FIG. 9 is a circuit diagram illustrating a pixel circuit of an organic light emitting display according to another exemplary embodiment of the present invention;

[0047] FIG. 10 is a circuit diagram illustrating a pixel circuit of an organic light emitting display according to a still another exemplary embodiment of the present invention;

[0048] FIG. 11 is a drive timing diagram of the pixel circuit as shown in FIG. 10; and

[0049] FIG. 12 is a circuit diagram illustrating a pixel circuit of an organic light emitting display according to a further still another exemplary embodiment of the present invention.

DETAILED DESCRIPTION OF PREFERRED EMBODIMENTS

[0050] Hereinafter, preferred embodiments of the present invention will be described in detail with reference to the accompanying drawing. The aspects and features of the present invention and methods for achieving the aspects and features will be apparent by referring to the embodiments to be described in detail with reference to the accompanying drawings. However, the present invention is not limited to the embodiments disclosed hereinafter, but can be implemented in diverse forms. The matters defined in the description, such as the detailed construction and elements, are nothing but specific details provided to assist those of ordinary skill in the art in a comprehensive understanding of the invention, and the present invention is only defined within the scope of the appended claims. In the entire description of the present invention, the same drawing reference numerals are used for the same elements across various figures. In addition, a term of "electrically coupled" means not only "directly coupled" but also "coupled via other interposing element".

[0051] FIG. 2 shows a block diagram illustrating an organic light emitting display according to the present invention.

[0052] Referring to FIG. 2, the organic light emitting display 100 includes a scan driver 110, a data driver 120, an emission control driver 130, an organic light emitting display panel 140 (hereinafter, referred to as "panel").

[0053] The scan driver **110** can sequentially supply scan signals to the panel **140** through a plurality of scan lines Scan[1], Scan[2] to Scan[n]. The data driver **120** can supply data signals to the panel **140** through a plurality of data lines Data[1], Data[2] to Data[m].

[0054] The emission control driver **130** can sequentially supply emission control signals to the panel **140** through a plurality of emission control lines Em[1], Em[2] to Em[n]. In addition, the emission control driver **130** can control a pulse width of the emission control signal, and control the number of pulse generated in one period. A pixel circuit **141** connected to the emission control lines Em[1], Em[2] to Em[n] can receive the emission control signal and determine a timing for allowing current generated in the pixel circuit **141** to flow to a light emitting device. Here, circuits of the emission control driver **130**, scan driver **110** and data driver **120** may be formed of a transistor the same as that of the pixel circuit. Thus, the circuits may be formed on a substrate without an additional process when the panel is formed. In other words, the circuits may not be formed in a separate chip type.

[0055] In addition, the panel **140** may include the plurality of scan lines Scan[1], Scan[2] to Scan[n] and plurality of emission control lines Em[1], Em[2] to Em[n] arranged in a row direction, and the plurality of data lines Data[1], Data[2] to Data[m] arranged in a column direction, and pixel circuits **141** defined by the plurality of scan lines Scan[1], Scan[2] to Scan[n], data lines Data[1], Data[2] to Data[m], and emission control lines Em[1], Em[2] to Em[n].

[0056] The pixel circuit may be formed in a pixel region defined by two adjacent scan lines (or emission control lines) and two adjacent data lines. Of course, as described above, the scan signal may be supplied to the scan lines Scan[1], Scan[2] to Scan[n] from the scan driver **110**, and the data signal may be supplied to the data lines Data[1], Data [2] to Data [m] from the data driver **120**, and the emission control signal may be supplied to the emission control lines Em[1], Em[2] to Em[n].

[0057] FIG. 3 shows a circuit diagram illustrating a pixel circuit of an organic light emitting display according to one exemplary embodiment of the present invention.

[0058] Referring to FIG. 3, the pixel circuit of the organic light emitting display includes a scan line Scan[n], a previous scan line Scan[n-1], a data line Data[m], an emission control line Em[n], a threshold voltage compensation line Th, a negative annealing line NA, a first voltage line ELVDD, a second voltage line ELVSS, a drive transistor M_{DR} , a first switching element S1, a second switching element S2, a third switching element S3, a fourth switching element S4, a fifth switching element S5, a first capacitive element C1, a second capacitive element C2 and an organic light emitting diode (OLED).

[0059] The scan line Scan[n] supplies a scan signal selecting the OLED for emission to a control electrode of the first switching element S1. Of course, the scan line Scan[n] is electrically coupled to the scan driver **110** (see FIG. 2) generating the scan signal.

[0060] The previous scan line Scan[n-1] is indicated as Scan[n-1] in a viewpoint that it uses a previously selected 'n-1' th scan line in common. The previous scan line Scan [n-1] is electrically coupled to a control electrode of the second switching element S2 for controlling the second switching element S2. The second switching element S2 connects the drive transistor M_{DR} in a diode structure when a high level previous scan signal is applied to the control electrode thereof.

[0061] The data line Data[m] supplies a data signal (voltage) determining a brightness of emission to the first switching element S1. Of course, the data line Data[m] may be electrically coupled to the data driver **120** (See FIG. 2) generating the data voltage.

[0062] The emission control line Em[n] is electrically coupled to a control electrode of the fifth switching element S5 and controls an emitting time of the OLED substantially by controlling the fifth switching element S5. Of course, the emission control line Em[n] is electrically coupled to the emission control driver **130** (See FIG. 2) generating the emission control signal.

[0063] The threshold voltage compensation line Th is electrically coupled to a control electrode of the third switching element S3 and controls the third switching element S3, thereby allowing the first capacitive element C1 to store a threshold voltage of the drive transistor M_{DR} in an emission drive period T_1 (see FIG. 4). The threshold voltage compensation line Th controls the third switching element S3 for applying the data voltage to a second electrode of the drive transistor M_{DR} in a negative annealing period T_2 (see FIG. 4).

[0064] The negative annealing line NA is electrically coupled to a control electrode of the fourth switching element S4 and controls the second voltage to be applied to the control electrode of the drive transistor M_{DR} by controlling the fourth switching element S4.

[0065] The first voltage line ELVDD applies a first voltage to the OLED.

[0066] The second voltage line ELVSS applies a second voltage to the OLED. Here, the first voltage is high level than the second voltage.

[0067] A first electrode of the drive transistor M_{DR} is electrically coupled to the first voltage line ELVDD, and a second electrode thereof is electrically coupled between the first electrode of the fifth switching element S5 and the second electrode of the third switching element S3, and a control electrode thereof is electrically coupled to the first electrode of the first capacitive element C1. Here, the second electrode of the first capacitive element C1 is electrically coupled to the data line Data[m] to apply the data signal the control electrode of the drive transistor M_{DR} . The drive transistor M_{DR} is an N type transistor. When a data signal of a high level (or positive voltage) is applied through the control electrode, the drive transistor M_{DR} is turned on to supply a predetermined amount of voltage from the first voltage line ELVDD to the OLED. On the other hand, even if a low level scan signal is applied to the control electrode of the first switching element S1 and the drive transistor M_{DR} is turned off, the data signal of a high level (or positive voltage) is continuously applied to the control electrode of the drive transistor M_{DR} for a predetermined time by charged voltage of the second capacitive element C2 because the second electrode of the first capacitive element C1 and the first electrode of the second capacitive element C2 are charged by the data signal of the high level supplied to N2 between them.

[0068] Here, the drive transistor M_{DR} may be any one selected from an amorphous silicon thin film transistor, a poly-silicon thin film transistor, an organic thin film transistor, a nano thin film transistor, an oxide thin film transistor and its equivalents, but not limited thereto.

[0069] In addition, when the drive transistor M_{DR} is a poly-silicon thin film transistor, the drive transistor M_{DR} can be formed by any one method selected from a laser crystallization, a metal induced crystallization, a high pressure crystal-

lization, a high temperature crystallization, a direct deposition and its equivalents, but not limited thereto.

[0070] The laser crystallization method crystallizes amorphous silicon by irradiating, for example, excimer laser to the amorphous silicon. The metal induced crystallization method starts crystallization from metal by placing, for example, metal on the amorphous silicon and heating at a predetermined temperature. The high pressure crystallization method crystallizes the amorphous silicon by applying, for example, a predetermined pressure to the amorphous silicon.

[0071] In addition, when the drive transistor M_{DR} is manufactured by the metal induced crystallization, the drive transistor M_{DR} may further include any one selected from nickel (Ni), cadmium (Cd), cobalt (Co), titanium (Ti), palladium (Pd), tungsten (W) and its equivalents.

[0072] The first electrode (drain or source electrode) of the first switching element S1 is electrically coupled to the data line Data[m], and the second electrode (source or drain electrode) thereof is electrically coupled to N2 between the second electrode of the first capacitive element C1 and the first electrode of the second capacitive element C2 and a control electrode thereof is electrically coupled to a scan line Scan[n]. When a high level scan signal is applied to the control electrode of the first switching element S1, the first switching element S1 is turned on to supply the data signal applied from the data line Data[m] to N2 between the second electrode of the first capacitive element C1 and the first electrode of the second capacitive element C2.

[0073] The first electrode of the second switching element S2 is electrically coupled between a first electrode N1 of the first capacitive element C1 and the control electrode of the drive transistor M_{DR} , and the second electrode thereof is electrically coupled between the first electrode of the drive transistor M_{DR} and the first voltage line ELVDD, and the control electrode thereof is electrically coupled to the previous scan line Scan[n-1]. When a high level previous scan signal is applied to the control electrode of the second switching element S2, the second switching element S2 is turned on to connect the drive transistor M_{DR} in the diode structure.

[0074] The first electrode of the third switching element S3 is electrically coupled between the second electrode of the first switching element S1 and a second electrode of the first capacitive element C1 and a first electrode of the second capacitive element C2, and the second electrode thereof is electrically coupled between the second electrode of the drive transistor M_{DR} and a first electrode of the fifth switching element S5, and the control electrode thereof is electrically coupled to the threshold voltage compensation line Th. When a high level threshold voltage compensation signal is applied to the control electrode of the third switching element S3, the third switching element S3 is turned on. Then, the third switching element S3 stores a voltage corresponding to the threshold voltage of the drive transistor M_{DR} in the first capacitive element C1 from the first voltage in the emission drive period, or applies the data signal to the second electrode of the drive transistor MDR in the negative annealing period.

[0075] The first electrode of the fourth switching element S4 is electrically coupled between the control electrode of the drive transistor MDR and the first electrode N1 of the first capacitive element C1, and the second electrode thereof is electrically coupled between the second electrode of the second capacitive element C2 and the second voltage line ELVSS, and the control electrode thereof is electrically coupled to the negative annealing line NA. When a negative

annealing signal is applied to the control electrode of the fourth switching element S4, the fourth switching element S4 is turned on to apply the second voltage to the control electrode.

[0076] The first electrode of the fifth switching element S5 is electrically coupled to the second electrode of the drive transistor MDR, and the second electrode thereof is electrically coupled to the OLED, and the control electrode thereof is electrically coupled to the emission control line Em[n]. When a high level emission control signal is applied to the control electrode of the fifth switching element S5, the fifth switching element S5 is turned on to apply a drive current of the drive transistor MDR to the OLED.

[0077] The first electrode of the first capacitive element C1 is electrically coupled between the control electrode of the drive transistor MDR and the second switching element S2, and a second electrode thereof electrically coupled between the first switching element S1, third switching element S3 and the second capacitive element C2. The first capacitive element C1 stores a voltage corresponding to a voltage difference between the first and second electrodes of the first capacitive element C1.

[0078] The first electrode of the second capacitive element C2 is electrically coupled between the first capacitive element C1 and first and third switching element S3s, and a second electrode thereof electrically coupled between the second electrode of the fourth switching element S4 and the second voltage line ELVSS. The second capacitive element C2 stores a voltage corresponding to a voltage difference between the first and second electrodes of the second capacitive element C2.

[0079] An anode of the OLED may be electrically coupled to the second electrode of the fifth switching element S5, and a cathode thereof may be electrically coupled to the second voltage line ELVSS. The OLED emits light of a predetermined brightness by current controlled through the drive transistor MDR.

[0080] The OLED includes an emitting layer (EML, see FIG. 1). The emitting layer may be any one selected from fluorescent material, phosphorescent material and its equivalents, but not limited thereto. In addition, the emitting layer (EML) may be any one selected from red, green, blue emitting materials and its equivalents, but not limited thereto.

[0081] FIG. 4 shows a drive timing diagram of the pixel circuit as shown in FIG. 3. Referring to FIG. 4, one frame of the drive timing of the pixel circuit can be divided into first and second periods. More particularly, one frame is constituted of an emission drive period T_1 and a negative annealing period T_2 . Desirably, a ratio of the emission drive period T_1 to a negative annealing period T_2 may be 1:1, but not limited thereto.

[0082] The emission drive period T_1 is a period in which actually the OLED emits light of a predetermined brightness and simultaneously a predetermined data signal is applied to the control electrode of the drive transistor MDR. The negative annealing period T_2 is a period in which a signal having polarity opposite to the data signal applied to the control electrode of the drive transistor MDR in the emission drive period T_1 is applied for annealing under the condition that the OLED is turned off. Here, the negative annealing period T_2 is called as negative annealing because the signal having polarity opposite to the data signal applied in the emission drive period T_1 is applied for annealing. The emission drive period T_1 is constituted of a threshold voltage compensation period

T_{11} , a data recording period T_{12} and an emitting period T_{13} . The negative annealing period T_2 is constituted of a delay period T_{21} , an annealing signal recording period T_{22} and an annealing period T_{23} .

[0083] FIG. 5 shows a circuit diagram illustrating an operation of the pixel circuit during a threshold voltage compensation period (T_{11}) of an emitting drive period (T_1) of the pixel circuit as shown in FIG. 4. Operation of the pixel circuit will be explained with reference to the timing diagram of FIG. 4.

[0084] In the threshold voltage compensation period T_{11} , a high level previous scan signal is applied to the previous scan line $Scan[n-1]$ to turn on the second switching element S_2 , and a high level threshold voltage compensation signal is applied to the threshold voltage compensation line Th to turn on the third switching element S_3 , and a high level emission control signal is applied to the emission control line $Em[n]$ to turn on the fifth switching element S_5 . A low level signal is applied to the scan line $Scan[n]$ and negative annealing line NA to turn off the first and fourth switching elements S_1 and S_4 .

[0085] The second switching element S_2 is turned on to connect the drive transistor MDR in the diode structure. The third switching element S_3 is turned on to apply a voltage difference between the first voltage and the threshold voltage of the drive transistor MDR to N_2 between the first and second capacitive elements C_1 and C_2 .

[0086] The first electrode N_1 of the first capacitive element C_1 is electrically coupled to the first voltage line $ELVDD$, and the second electrode thereof is electrically coupled to the second electrode of the drive transistor MDR because the third switching element S_3 is turned on. In this time, the drive transistor MDR is connected in the diode structure. Accordingly, a voltage corresponding to the difference between the first voltage line $ELVDD$ and the second electrode of the drive transistor MDR is applied to the first capacitive element C_1 . In this time, the voltage difference between the first and second electrodes N_1 and N_2 of the first capacitive element C_1 is the same as the threshold voltage of the drive transistor MDR. Accordingly, the first capacitive element C_1 stores the threshold voltage of the drive transistor MDR.

[0087] FIG. 6 shows a circuit diagram illustrating an operation of the pixel circuit during a data recording period T_{12} of the emitting drive period T_1 of the pixel circuit as shown in FIG. 4. Operation of the pixel circuit will be explained with reference to the timing diagram of FIG. 4.

[0088] In the data recording period T_{12} , a high level scan signal is applied to the scan line $Scan[n]$ to turn on the first switching element S_1 , and a high level emission control signal is applied to the emission control line $Em[n]$ to turn on the fifth switching element S_5 . A low level signal is applied to the previous scan line $Scan[n-1]$, threshold voltage compensation line Th and negative annealing line NA to turn off the first, third and fourth switching elements S_1 , S_3 and S_4 .

[0089] When the first switching element S_1 is turned on to apply a data signal of a high level (positive voltage) applied from the data line $Data[m]$ to N_2 between the second electrode of the first capacitive element C_1 and the first electrode of the second capacitive element C_2 , the first capacitive element C_1 applies a voltage corresponding to a sum of the threshold voltage of the drive transistor MDR stored in the first capacitive element C_1 in the threshold voltage compensation period T_{11} and the data signal (positive voltage) applied to the second electrode of the first capacitive element

C_1 , to the control electrode of the drive transistor MDR, and the fifth switching element S_5 is turned on to apply a voltage applied from the drive transistor MDR to the OLED. The data signal is applied to the first electrode N_2 of the second capacitive element C_2 , and a second electrode thereof is electrically coupled to the second voltage line $ELVSS$. Thus, the second capacitive element C_2 stores the data signal.

[0090] The current transmitted to the OLED in the data recording period T_{12} is represented by the following equation 2:

[Equation 2]

$$\begin{aligned} I_{OLED} &= \frac{\beta}{2}(V_{GS} - V_{TH})^2 \\ &= \frac{\beta}{2}(V_G - V_S - V_{TH})^2 \\ &= \frac{\beta}{2}(V_{DATA} + V_{TH} - V_S - V_{TH})^2 \\ &= \frac{\beta}{2}(V_{DATA} - V_S)^2 \end{aligned} \quad 2$$

[0091] Where V_{GS} is a voltage between gate and source of a drive transistor M_{DR} , V_G is a gate voltage of the drive transistor MDR, and V_S is a source voltage of the drive transistor M_{DR} , and V_{DATA} is a data signal (positive voltage) applied from a data line $Data[m]$, and V_{TH} is a threshold voltage of the drive transistor M_{DR} , and β is a constant, and I_{OLED} is a drive current flowing in an OLED.

[0092] As shown in the equation 1, the threshold voltage is cancelled by a gate voltage of the drive transistor M_{DR} stored in the first capacitive element C_1 during the threshold voltage compensation period T_{11} and thus disappears from the drive current. Accordingly, the OLED of each pixel circuit 141 (See FIG. 2) emits light of the same brightness irrelevant to a difference between threshold voltages of each drive transistor M_{DR} , thereby realizing the organic light emitting display of a high grayscale. In addition, it is possible to prevent brightness of the organic light emitting display from being changed by the threshold voltage degradation of the drive transistor M_{DR} with the lapse of time.

[0093] FIG. 7 shows a circuit diagram illustrating an operation of the pixel circuit during an emitting period T_{13} of the emitting drive period T_1 of the pixel circuit as shown in FIG. 4. Operation of the pixel circuit will be explained with reference to the timing diagram of FIG. 4.

[0094] In the emitting period T_{13} , a high level scan signal is applied to the emission control line $Em[n]$ to turn on the fifth switching element S_5 . A low level signal is applied to the scan line $Scan[n]$, previous scan line $Scan[n-1]$, threshold voltage compensation line Th and negative annealing line NA to turn off the first, second, third and fourth switching elements S_1 , S_2 , S_3 and S_4 .

[0095] The drive transistor M_{DR} is operated the same as the operation the data recording period T_{12} by the data signal stored in the second capacitive element C_2 during the data recording period T_{12} until the fifth switching element S_5 is turned off even if the first switching element S_1 is turned off to interrupt the data signal applied to N_2 between the second electrode of the first capacitive element C_1 and the first electrode of the second capacitive element C_2 . Thus, the same current as that in the data recording period T_{12} flows to the OLED, thereby allowing the OLED to emit light.

[0096] FIG. 8 shows a circuit diagram illustrating an operation of the pixel circuit during a negative annealing period T_2 of the pixel circuit as shown in FIG. 4. Operation of the pixel circuit will be explained with reference to the timing diagram of FIG. 4.

[0097] The negative annealing period T_2 is constituted of a delay period T21, an annealing signal recording period T22 and an annealing period T23. The circuit diagram illustrating the operation of the pixel circuit of FIG. 4 is related to the annealing signal recording period T22.

[0098] The delay period T_{21} is a period in which a high level scan signal is applied to the previous scan line Scan[n-1] before the annealing signal recording period T22 and annealing period T23. The second switching element S2 is operated by using the previous scan line Scan[n-1] in the emission drive period T_1 , and the previous scan signal of the previous scan line Scan[n-1] is a signal that is identically applied in a high level before the scan signal of the scan line Scan[n] is applied in a high level. The previous scan signal is used in the emission drive period T_1 , but not used in the negative annealing period T_2 . Thus, the pixel circuit is not operated in the delay period T21.

[0099] Operation of the pixel circuit during the annealing signal recording period T22 is shown in FIG. 8. In the annealing signal recording period T22, a high level scan signal is applied to the scan line Scan[n] to turn on the first switching element S1, and a high level threshold voltage compensation signal is applied to the threshold voltage compensation line Th to turn on the third switching element S3. A high level signal is applied to the negative annealing line NA to turn on the fourth switching element S4. A low level signal is applied to the previous scan line Scan[n-1] and emission control line Em[n] to turn off the second and fifth switching elements S2 and S5.

[0100] The first switching element S1 is turned on to apply a data signal of a high level (positive voltage) applied from the data line Data[m] to N2 between the second electrode of the first capacitive element C1 and the first electrode of the second capacitive element C2. The third switching element S3 is turned on to apply a data signal to the second electrode of the drive transistor M_{DR} . The fourth switching element S4 is turned on to apply the second voltage ELVSS to the second electrode of the drive transistor M_{DR} . In other words, a data signal of a low level (negative voltage) opposite to the data signal of the high level (positive voltage) applied to the drive transistor M_{DR} in the data recording period T12 is applied as the voltage between the control electrode and second electrode of the drive transistor M_{DR} . The drive transistor M_{DR} is applied with the data signal of the low level (negative voltage) opposite to that of the emission drive period T_1 and negatively annealed.

[0101] The fourth switching element S4 is turned on to apply the second voltage ELVSS to the first electrode N1 of the first capacitive element C1, and apply a data signal of a high level (positive voltage) to the second electrode N2 thereof. In this time, a voltage corresponding to a voltage difference between the first and second electrodes of the first capacitive element C1 is stored in the first capacitive element C1.

[0102] The data signal of the high level (positive voltage) is applied to the first electrode N2 of the second capacitive element C2, and the second voltage ELVSS is applied to the second electrode N3 thereof. Thus, a voltage corresponding

to a voltage difference between the first and second electrodes of the second capacitive element C2 is stored in the second capacitive element C2.

[0103] In the annealing period T23, a high level threshold voltage compensation signal is applied to the threshold voltage compensation line Th to turn on the third switching element S3. A low level signal is applied to the emission control line Em[n], scan line Scan[n], previous scan line Scan[n-1], and negative annealing line NA to turn off the first, second, fourth and fifth switching elements S1, S2, S4 and S5.

[0104] The first switching element S1 is turned off to interrupt the data signal applied to the N2 between the second electrode of the first capacitive element C1 and the first electrode of the second capacitive element C2. The fourth switching element S4 is turned off to interrupt the second voltage applied to the control electrode of the drive transistor M_{DR} . The data signal stored in the first and second capacitive elements C1 and C2 in the annealing signal recording period T22 is applied to the drive transistor M_{DR} until the third switching element S3 is turned off. Thus, the drive transistor M_{DR} is continuously annealed until one frame is terminated under the condition that it is completely turned off.

[0105] As described above, in the emission drive period T_1 and negative annealing period T_2 , the data signal of positive voltage and data signal of negative voltage are sequentially applied between the control electrode and second electrode of the drive transistor M_{DR} . In other words, the data signal of negative voltage used in emitting is supplied to the control electrode of the drive transistor M_{DR} . Accordingly, if the previous data signal is low, a low negative voltage is applied to the control electrode of the drive transistor M_{DR} . On the contrary, if the previous data signal is high in the previous emitting, a high negative voltage is applied to the control electrode of the drive transistor M_{DR} . Thus, the non-uniform brightness phenomenon of the entire panel can be prevented by negatively annealing in proportional to the data signal supplied to each pixel circuit.

[0106] As described above, the ratio of the emission drive period T_1 to the negative annealing period T_2 in one frame can be variously controlled to 1:1 or other ratio. For example, when the ratio of the emission drive period T_1 to the negative annealing period T_2 is 1:1, the data signal is applied in a speed of 120 frames per second for realizing a screen of 60 frames per second, and the same data voltage is applied to each pixel once in the emitting period, and once more in the negative annealing period. Accordingly, there is the negative annealing period between the emission drive period of the pixel and next emission drive period. In the negative annealing period, emission is not performed. Accordingly, a first image (for example, a black image) is naturally displayed between frames. Thus, motion blur phenomenon is naturally prevented, and a high contrast ration can be obtained.

[0107] FIG. 9 shows a circuit diagram illustrating a pixel circuit of an organic light emitting display according to another exemplary embodiment of the present invention.

[0108] Referring to FIG. 9, the pixel circuit of the organic light emitting display is similar to that shown in FIG. 3 except that an OLED is electrically coupled between a first voltage line ELVDD and a first electrode of a drive transistor M_{DR} . The OLED may be provided between a fifth switching element S5 and a second voltage line ELVSS as shown in FIG. 3, or may be provided between the first voltage line ELVDD and the drive transistor M_{DR} as shown in FIG. 9 in consideration

of circuit design. Operation of the pixel circuit of FIG. 9 is the same as that of the pixel circuit as described above in FIGS. 4 to 8.

[0109] FIG. 10 shows a circuit diagram illustrating a pixel circuit of an organic light emitting display according to a still another exemplary embodiment of the present invention.

[0110] Referring to FIG. 10, the pixel circuit of an organic light emitting display is similar to that shown in FIG. 3 except that a drive transistor M_{DR} and all switching elements are a P type channel transistor differently from the pixel circuit of FIG. 3 whose drive transistor M_{DR} and all switching elements are the N type channel transistor. Accordingly, electrical coupling relationship between each element is somewhat different.

[0111] For example, a first electrode of the drive transistor M_{DR} is electrically coupled to a second electrode of a fifth switching element S5, a second electrode thereof is electrically coupled to a second voltage line ELVSS. In addition, an anode of an OLED may be electrically coupled to a first voltage line ELVDD, and a cathode thereof may be electrically coupled to a first electrode of the fifth switching element S5. In addition, a first electrode of a second switching element S2 is electrically coupled to a control electrode of the drive transistor M_{DR} , and a second electrode thereof is electrically coupled to the second voltage line ELVSS. In addition, a first electrode of a fourth switching element S4 is electrically coupled to the first voltage line ELVDD, and a second electrode thereof is electrically coupled to the second voltage line ELVSS. In addition, a first electrode of a second capacitive element C2 is electrically coupled to the first voltage line ELVDD, and a second electrode thereof is electrically coupled between the first and third switching elements S1 and S3. Other constructions are the same as the pixel circuit shown in FIG. 3.

[0112] FIG. 11 shows a drive timing diagram of the pixel circuit as shown in FIG. 10.

[0113] As shown in FIG. 11, the operation of the pixel circuit shown in FIG. 10 is similar to those of the pixel circuit and drive timing operation shown in FIGS. 3 and 4. Merely, the drive transistor M_{DR} and switch devices are turned on when a low level signal is applied to the control electrodes of them because they are the P type channel transistor. In addition, the data signal applied from a data line Data[m] is also low level.

[0114] One frame of the pixel circuit shown in FIG. 10 is constituted of an emission drive period and a negative annealing period. In other words, in the emission drive period T_1 , a data signal of a low level (or negative voltage) is applied to the control electrode of the drive transistor M_{DR} . In the negative annealing period T_2 , the first voltage is applied to the control electrode of the drive transistor M_{DR} , and the data signal of a high level (or positive voltage) is applied to the first electrode thereof. In other words, the negative and positive voltages are alternatively and sequentially applied between the control electrode and first electrode of the drive transistor M_{DR} in the emission drive period T_1 and negative annealing period T_2 .

[0115] FIG. 12 shows a circuit diagram illustrating a pixel circuit of an organic light emitting display according to a further still another exemplary embodiment of the present invention. Referring to FIG. 12, the pixel circuit of the organic light emitting display is similar to that shown in FIG. 10 except that an OLED is electrically coupled between a second electrode of a drive transistor M_{DR} and a second voltage line ELVSS. The OLED may be provided between a first voltage

line ELVDD and a fifth switching element S5 as shown in FIG. 10, or may be provided between the drive transistor M_{DR} and the second voltage line ELVSS as shown in FIG. 12 in consideration of circuit design. Operation of the pixel circuit of FIG. 12 is the same as that of the pixel circuit of FIG. 10 as described above in FIG. 11.

[0116] As described above, the organic light emitting display according to the present invention produces the following effects.

[0117] First, the organic light emitting display can minimize the threshold voltage change of the drive transistor, in other words, degradation phenomenon and improve the overall brightness uniformity of the display by dividing the image display period of one frame into first and second periods, and applying a positive (or negative) voltage as the data signal to the control electrode of the drive transistor in the first period to allow the organic light emitting diode to emit light, and, in the second period, applying a negative (or positive) voltage opposite to the voltage applied to the control electrode of the drive transistor in the first period to turn off the organic light emitting diode, and simultaneously, negatively annealing the drive transistor.

[0118] Second, the organic light emitting display can prevent the motion blur phenomenon and realize a high contrast ratio by controlling the ratio of the emitting drive period to a negative annealing period in the image display period of one frame to 1:1 or other ratio and displaying the first image between one frame and a next frame naturally.

[0119] Third, the organic light emitting display can compensate the change and difference of the threshold voltage of the drive transistor by connecting the drive transistor in the diode structure and storing the threshold voltage of the drive transistor in the capacitive element electrically coupled to the drive transistor and applying the summed voltage of the threshold voltage and the data voltage to the control electrode of the drive transistor when the data voltage is applied to the drive transistor.

[0120] It should be understood by those of ordinary skill in the art that various replacements, modifications and changes in the form and details may be made therein without departing from the spirit and scope of the present invention as defined by the following claims. Therefore, it is to be appreciated that the above described embodiments are for purposes of illustration only and are not to be construed as limitations of the invention.

What is claimed is:

1. An organic light emitting display, comprising:

- a first switching element having a control electrode is electrically coupled to a scan line, being electrically coupled between a data line and a first voltage line for transmitting a data signal;
- a drive transistor having a control electrode is electrically coupled to the first switching element, being electrically coupled between the first voltage line and a second voltage line;
- an organic light emitting diode electrically coupled to the drive transistor, displaying an image by a current supplied through the drive transistor;
- a first capacitive element electrically coupled between the control electrode of the drive transistor and the first switching element;
- a second capacitive element electrically coupled between the first capacitive element and the second voltage line;

- a second switching element electrically coupled between the first voltage line and the control electrode of the drive transistor;
- a third switching element electrically coupled between the first switching element and the drive transistor;
- a fourth switching element electrically coupled between the control electrode of the drive transistor and the second voltage line; and
- a fifth switching element electrically coupled between the drive transistor and the second voltage line.
2. The organic light emitting display of claim 1, wherein a first electrode of the first switching element is electrically coupled to the data line, and a second electrode of the first switching element is electrically coupled between a first electrode of the third switching element and a second electrode of the first capacitive element and a first electrode of the second capacitive element.
3. The organic light emitting display of claim 1, wherein a control electrode of the second switching element is electrically coupled to a previous scan line, and a first electrode of the second switching element is electrically coupled between a first electrode of the fourth switching element and a first electrode of the first capacitive element and the control electrode of the drive transistor, and a second electrode of the second switching element is electrically coupled between the first voltage line and the first electrode of the drive transistor.
4. The organic light emitting display of claim 1, wherein a control electrode of the third switching element is electrically coupled to a threshold voltage compensation line, and a first electrode of the third switching element is electrically coupled between a second electrode of the first switching element and the second electrode of the first capacitive element, and a second electrode of the third switching element is electrically coupled between the drive transistor and the fifth switching element.
5. The organic light emitting display of claim 1, wherein a control electrode of the fourth switching element is electrically coupled to a negative annealing line, and a first electrode of the fourth switching element is electrically coupled between the control electrode of the drive transistor and the first electrode of the second switching element and the first electrode of the first capacitive element, and a second electrode of the fourth switching element is electrically coupled to the second voltage line.
6. The organic light emitting display of claim 1, wherein a control electrode of the fifth switching element is electrically coupled to an emission control line, and a first electrode of the fifth switching element is electrically coupled between the second electrode of the drive transistor and the second electrode of the third switching element, and a second electrode of the fifth switching element is electrically coupled to the second voltage line.
7. The organic light emitting display of claim 1, wherein an anode of the organic is light emitting diode is electrically coupled to the fifth switching element, a cathode of the organic light emitting diode is electrically coupled to the second voltage.
8. The organic light emitting display of claim 1, wherein an anode of the organic light emitting diode is electrically coupled to the first voltage line, a cathode of the organic light emitting diode is electrically coupled between the first electrode of the drive transistor and the second electrode of the second switching element.
9. The organic light emitting display of claim 1, wherein a first electrode of the first capacitive element is electrically coupled between the first electrode of the second switching element and the control electrode of the drive transistor and the first electrode of the fourth switching element, and a second electrode of the first capacitive element is electrically coupled between the second electrode of the first switching element and the first electrode of the third switching element and the first electrode of the second capacitive element.
10. The organic light emitting display of claim 1, wherein a first electrode of the second capacitive element is electrically coupled between the second electrode of the first capacitive element and the second electrode of the first switching element and the first electrode of the third switching element, and a second electrode of the second capacitive element is electrically coupled between the second electrode of the fourth switching element and the second voltage line.
11. The organic light emitting display of claim 1, wherein the first, second, third, fourth and fifth switching elements and the drive transistor are an N type channel transistor.
12. The organic light emitting display of claim 1, wherein when the second and fifth switching elements are turned off and the first, third and fourth switching elements are turned on during an image display period of one frame, a data signal is applied to the second electrode of the drive transistor, and the second voltage is applied to the control electrode of the drive transistor.
13. An organic light emitting display, comprising:
- a first switching element having a control electrode is electrically coupled to a scan line, being electrically coupled between a data line and a first voltage line for transmitting a data signal;
 - a drive transistor having a control electrode is electrically coupled to the first switching element, being electrically coupled between the first voltage line and a second voltage line;
 - an organic light emitting diode electrically coupled to the drive transistor, displaying an image by a current supplied through the drive transistor;
 - a first capacitive element electrically coupled between the control electrode of the drive transistor and the first switching element;
 - a second capacitive element electrically coupled between the first capacitive element and the first voltage line;
 - a second switching element electrically coupled between the second voltage line and the control electrode of the drive transistor;
 - a third switching element electrically coupled between the first switching element and the drive transistor;
 - a fourth switching element electrically coupled between the control electrode of the drive transistor and the first voltage line; and
 - a fifth switching element electrically coupled between the drive transistor and the first voltage line.
14. The organic light emitting display of claim 13, wherein a first electrode of the first switching element is electrically coupled to the data line, and a second electrode of the first switching element is electrically coupled between a first electrode of the third switching element and a first electrode of the first capacitive element and a second electrode of the second capacitive element.
15. The organic light emitting display of claim 13, wherein a control electrode of the second switching element is electrically coupled to a previous scan line, and a first electrode of

the second switching element is electrically coupled between a second electrode of the fourth switching element and a second electrode of the first capacitive element and the control electrode of the drive transistor, and a second electrode of the second switching element is electrically coupled between the second voltage line and the second electrode of the drive transistor.

16. The organic light emitting display of claim **13**, wherein a control electrode of the third switching element is electrically coupled to a threshold voltage compensation line, and a first electrode of the third switching element is electrically coupled between a second electrode of the first switching element and the first electrode of the first capacitive element and the second electrode of the second capacitive element, and a second electrode of the third switching element is electrically coupled between the drive transistor and the fifth switching element.

17. The organic light emitting display of claim **13**, wherein a control electrode of the fourth switching element is electrically coupled to a negative annealing line, and a first electrode of the fourth switching element is electrically coupled to the first voltage line, and a second electrode of the fourth switching element is electrically coupled between the control electrode of the drive transistor and the first electrode of the second switching element and the second electrode of the first capacitive element.

18. The organic light emitting display of claim **13**, wherein a control electrode of the fifth switching element is electrically coupled to an emission control line, and a first electrode of the fifth switching element is electrically coupled to the first voltage line, and a second electrode of the fourth switching element is electrically coupled between the first electrode of the drive transistor and the second electrode of the third switching element.

19. The organic light emitting display of claim **13**, wherein an anode of the organic light emitting diode is electrically coupled between the second electrode of the drive transistor

and the second electrode of the second switching element, and a cathode of the organic light emitting diode is electrically coupled to the second voltage.

20. The organic light emitting display of claim **13**, wherein an anode of the organic light emitting diode is electrically coupled to the first voltage line, a cathode of the organic light emitting diode is electrically coupled to the first electrode of the fifth switching element.

21. The organic light emitting display of claim **13**, wherein a first electrode of the first capacitive element is electrically coupled between the second electrode of the first switching element and the first electrode of the third switching element and the second electrode of the second capacitive element, and a second electrode of the first capacitive element is electrically coupled between the first electrode of the second switching element and the control electrode of the drive transistor and the second electrode of the fourth switching element.

22. The organic light emitting display of claim **13**, wherein a first electrode of the second capacitive element is electrically coupled between the first electrode of the fourth switching element and the first voltage line, and a second electrode of the second capacitive element is electrically coupled between the first electrode of the first capacitive element and the second electrode of the first switching element and the first electrode of the third switching element.

23. The organic light emitting display of claim **13**, wherein the first, second, third, fourth and fifth switching elements and the drive transistor are a P type channel transistor.

24. The organic light emitting display of claim **13**, wherein when the second and fifth switching elements are turned off and the first, third and fourth switching elements are turned on during an image display period of one frame, a data signal is applied to the first electrode of the drive transistor, and the first voltage is applied to the control electrode of the drive transistor.

* * * * *

专利名称(译)	有机发光显示器		
公开(公告)号	US20090027312A1	公开(公告)日	2009-01-29
申请号	US12/168204	申请日	2008-07-07
[标]申请(专利权)人(译)	韩敏KOO 韩相面		
申请(专利权)人(译)	韩敏KOO 韩相面		
当前申请(专利权)人(译)	韩敏KOO 韩相面		
[标]发明人	HAN MIN KOO HAN SANG MYEON		
发明人	HAN, MIN KOO HAN, SANG MYEON		
IPC分类号	G09G3/30		
CPC分类号	G09G3/3233 G09G2300/0819 G09G2320/066 G09G2300/0861 G09G2320/0261 G09G2300/0852		
优先权	1020070073427 2007-07-23 KR		
其他公开文献	US8149187		
外部链接	Espacenet USPTO		

摘要(译)

一种有机发光显示器，其可以使包括第一开关元件的驱动晶体管的劣化最小化，所述第一开关元件的控制电极电连接到扫描线，电连接在数据线和用于传输数据信号的第一电压线之间；驱动晶体管，其控制电极电耦合到第一开关元件，电耦合在第一和第二电压线之间；有机发光二极管，电耦合到驱动晶体管，通过驱动晶体管提供的电流显示图像；第一电容元件，电耦合在驱动晶体的控制电极和第一开关元件之间；第二电容元件，电耦合在第一电容元件和第二电压线之间；第二开关元件，电耦合在第一电压线和驱动晶体的控制电极之间；第三开关元件，电耦合在第一开关元件和驱动晶体管之间；第四开关元件，电连接在驱动晶体的控制电极和第二电压线之间；第五开关元件电连接在驱动晶体管和第二电压线之间。

